



## Digital Brake Module

### 1. Introduction

Thank you for purchasing this *Modell-Zug Elektronik* product. The *Brake Module* allows for automatic gradual start and stop operations of digital locomotives equipped with built-in braking and acceleration delay features. When placed at railroad signals or stations, the *Brake Module* provides extremely smooth, realistic train control. The *Brake Module* accomplishes this by signaling only the locomotive in its isolated track block to start or stop, without affecting the operation of any other locomotives in use. Locomotive headlights and additional functions also remain active when the train is stopped by the *Brake Module*. Activation of the *Brake Module* is simple to perform by applying a momentary voltage pulse from an analog switch box, circuit track, or digital accessory decoder such as the *MZE Decoder Z83/84* or Märklin k83. This feature allows the *Brake Module* to be universally adapted to layouts with either analog or digital accessory control. In addition, the *Brake Module* contains an auxillary set of switched contacts to supply feedback to a layout control panel or other logical functions. Please study the following manual in its entirety to gain full utility and enjoyment from this *Modell-Zug Elektronik* product.

### 2. Overview of Features

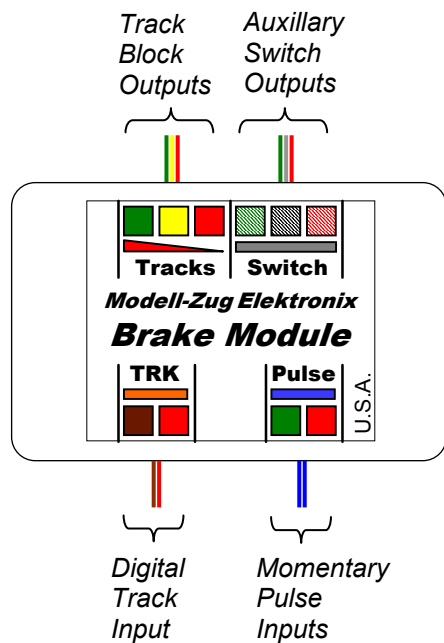

#### ***Mechanical Specifications***

Dimensions: W 2.50 in.; D 1.63 in.; H 0.81 in.  
Weight: 2 oz.

#### ***Electrical Specifications***

Power Consumption: 0.0W typ. (No Input Pulse); 1.3W max. (Input Pulse Applied)  
Input Voltage Range:  $\pm 22$ V max. (Digital Input)  
Output Current: 2A max. (Each Output)  
Output Voltage: 30V max. (Each Output)

### 3. Operating the Brake Module



#### 3.1 Installing the Track Blocks

In order to provide safe and reliable automatic train operation, the *Brake Module* requires three different track blocks: Transition, Brake, and Stop. Each of these track blocks must be completely electrically-isolated from each other as well as the rest of the layout. The first block is an electrical Transition track, which prevents the train's pickup shoe(s) from short-circuiting the Central Unit output to the *Brake Module's* "Brake" output when the module is set to Stop. The second block, Brake, applies the control voltage to the locomotive causing it to come to a gradual stop. The final block is an emergency Stop section that is an added safety measure in the event that a locomotive has not fully stopped by the end of the Brake section. When the *Brake Module* is set to Go, all three track sections are directly connected to the digital TRK input to avoid voltage discontinuities in the track. The procedure below outlines the installation of each track block:

1. Determine the required lengths of each isolated track block, based on your trains and application, as shown in Figure 1 below:

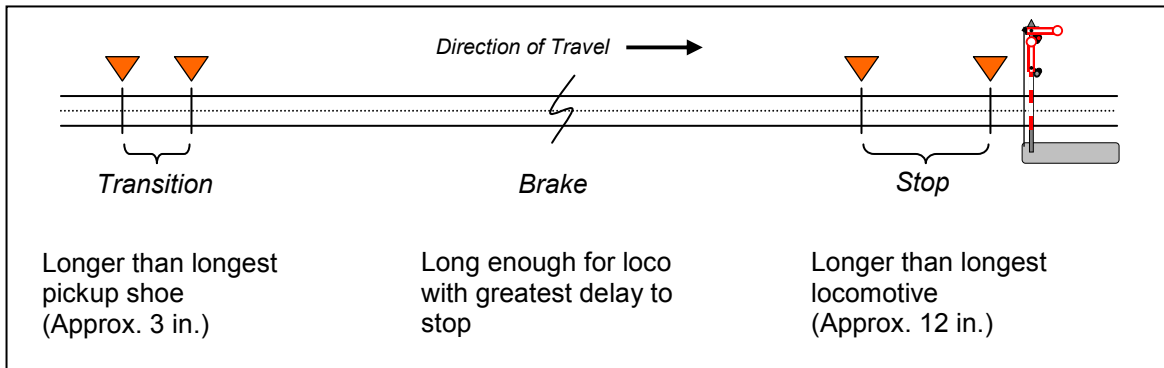

**Figure 1. Track Block Lengths**

2. Once the lengths of each track block have been established, the center rails must be isolated from each other and the layout. Power leads must also be installed on each block to allow subsequent connection to the *Brake Module* outputs. Depending on your preferred track system, the following Märklin components may be used to accomplish this. Please refer to the installation instructions included with these items.

74030	Center Rail Insulators	C-Track	
74040	Feeder Wire Set	C-Track	
74043	Signal Hookup Kit	C-Track	(Contains 74030 & 74040)
7522	Center Rail Insulators	K-Track	
7504	Center Rail Terminals	K-Track	

3. When all of the insulators, center rail feeder wires, and track have been installed, it is important to verify that each block is correctly isolated from one another. There are two simple methods that will verify proper isolation:
  - 3a. You may directly measure the resistance between each block using an ohmmeter, where you should measure >1MegOhm between each block and the layout.
  - 3b. Or, you may use a slow moving locomotive and sequentially connect each block to track power as follows: Starting with all three blocks disconnected, the train should stop when the pickup shoe is completely within the Transition section. Next, connect the Transition section to track power. The train should move into the Brake section and stop again. Lastly, connect the Brake section to track power, and the train should once again continue until it stops at the Stop section. Connecting the Stop section to track power should cause the train to start again and continue to the rest of the layout. If the locomotive stopped in the correct spot in each case, then all of the track blocks are properly isolated. If not, recheck all components, reinstall as necessary, and re-verify the isolation.

**MZE** 3.2 Connecting the Brake Module

The connections of the *Brake Module* are divided into four groups: TRK, Pulse, Tracks, and Switch. The TRK input is connected to the Central Unit or Booster output, which powers the *Brake Module* electronics and is distributed to the train that the module controls. The Pulse inputs program the state of the module (Stop or Go) and are activated by means of a momentary switch box, circuit track, digital accessory decoder, or other momentary pulse to digital power ground (outer track rails). The Tracks output set are connected to the three isolated track blocks (Transition, Brake, Stop), and control the train's movement. The Switch outputs are provided as auxillary contacts for feedback to a layout control panel or other optional functions. The following steps and figures illustrate the various connections between the *Brake Module* and layout.

1. Be sure that all power to the layout is switched OFF. Connect the *Brake Module's* Tracks output set to the corresponding track blocks created in Section 3.1, referring to Figure 2 below:

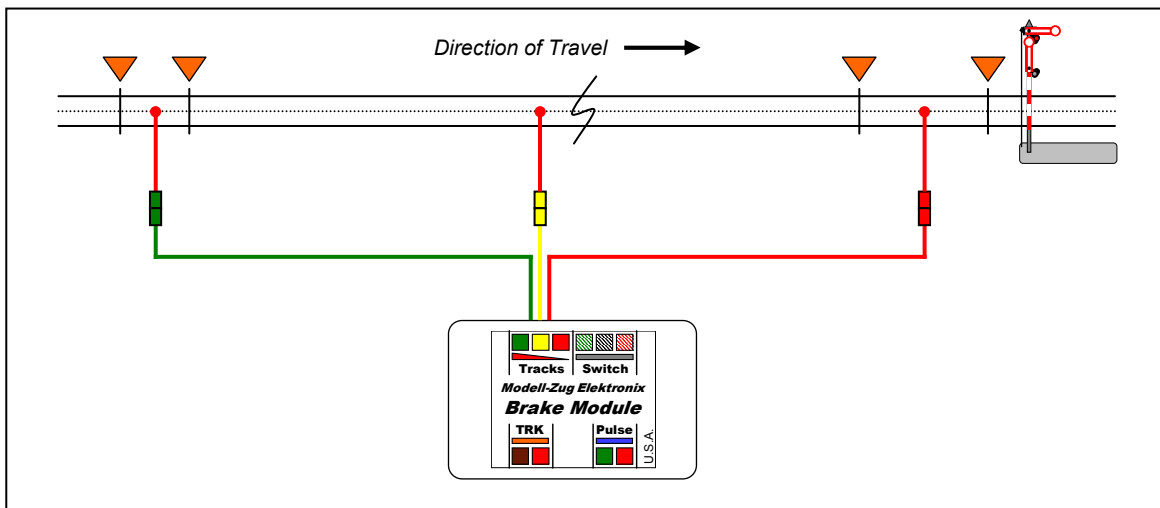

Figure 2. Track Block Connections

2. Next, the TRK and Pulse inputs are connected in one of the methods shown in Figure 3 below, in either analog or digital accessory control format:

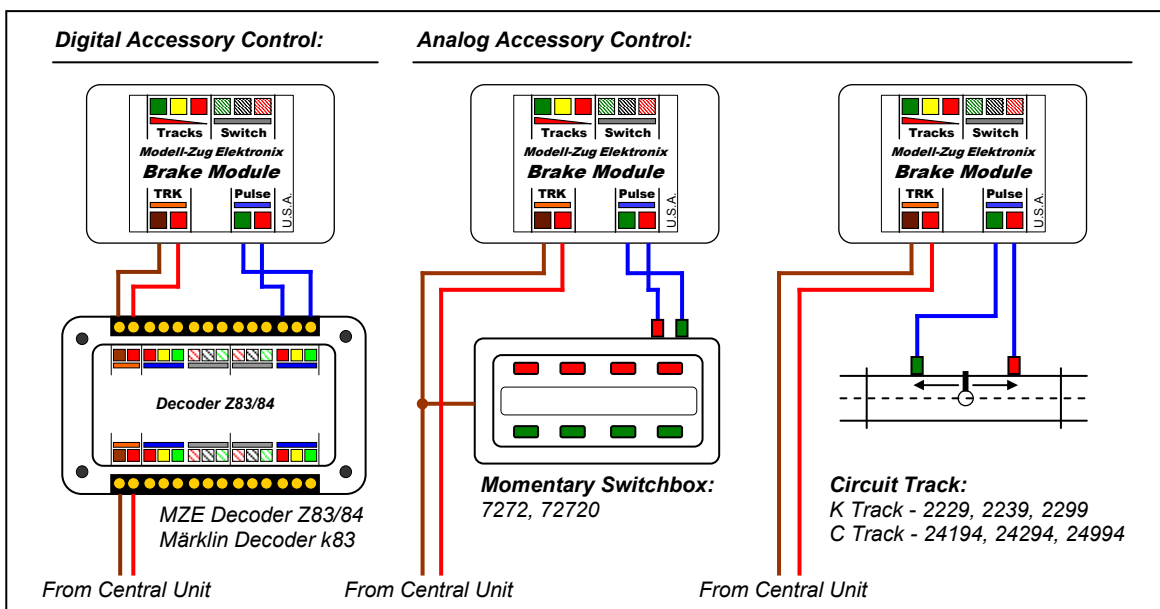

Figure 3. Input Connections

3. The Auxillary Switch may be used in a variety of applications for controlling additional accessories, logic functions, or feedback. Figure 4 below demonstrates some practical applications of the auxillary switch contacts. (Note: When connecting LEDs for control panel feedback, it is recommended to connect diodes such as the 1N4148 across each LED in anti-parallel as shown in Figure 4 to protect the LEDs against the reverse AC voltage swing.)

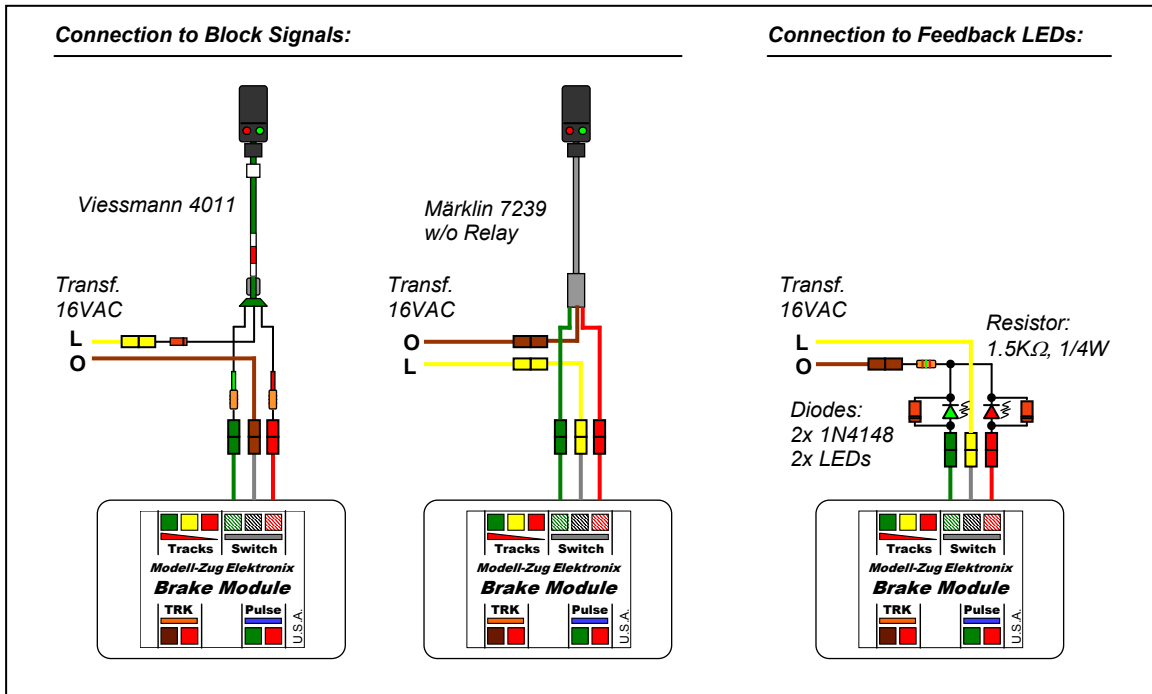

Figure 4. Auxillary Switch Connection Examples