

Signal Adapter

1. Introduction

Thank you for purchasing this *Modell-Zug Elektronik* product. The *Signal Adapter* was specially designed to provide universal operation of the new generation of Märklin color light signals 74371, 74380, and 74391. These signals possess a high degree of realistic detail and innovative technology, including ultra-bright LED lamps and wireless signal masts. The *Signal Adapter* allows one of these signals to be controlled by methods similar to that of the traditional Märklin 70- and 72- series signals. Remote control of the *Signal Adapter* is made possible by a momentary switch box, circuit track, or digital accessory decoder. The *Signal Adapter* will accept power from several different sources including a standard 16VAC transformer output, digital accessory decoder output, or digital track power. Train movement may also be controlled by the integrated switching contacts of the *Signal Adapter* for the 74371 Yard or 74391 Block signals. These features ensure direct replacement of traditional signals with the new generation of LED signals. Please study the following manual in its entirety to gain full utility and enjoyment from this *Modell-Zug Elektronik* product.

2. Overview of Features

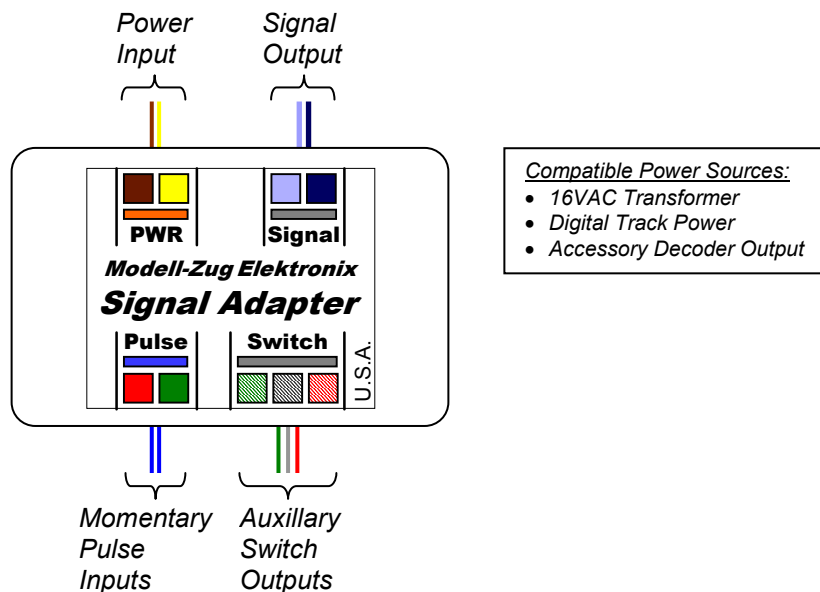

Mechanical Specifications

Dimensions: W 2.50 in.; D 1.63 in.; H 0.81 in.
Weight: 2 oz.

Electrical Specifications

Power Consumption: 0.25W typ. (No Input Pulse); 0.7W max. (Input Pulse Applied)
Power Input Range: $\pm 22V$ (16VAC) max.
Pulse Input Current: 30mA max. (Input Pulse Applied)
Output Current: 2A max. (Switch Output)
Output Voltage: 30V max. (Switch Output)

3. Operating the Signal Adapter

MZE 3.1 Installing the Signal Block, Mast, and Adapter

The Märklin 74- series signals are intended for use with the C track system, but are also K track compatible with some minor modifications. The necessary mounting hardware is supplied with each signal, including a mounting screw and wedges for leveling the signal base on both 3% and 5% grades. Installation of the signal mast requires disassembly of its 3-piece plastic base to gain access to the mast connector and mounting holes within the base itself. There is also an external clip molded into the base for mounting with C track, which is easily removed for use with the K track system. An insulated section of track must be installed in front of the signal to provide train control using the switch contacts of the *Signal Adapter*. The following steps and diagrams illustrate how to properly install the signal mast, track block, and the *Signal Adapter*.

3.1.1 Signal Track Block Installation:

- 1) Referring to Figure 1 below, install the signal block section in the desired location of the layout using the supplied center rail insulators and feeder wire for Märklin C-Track. The following Märklin components may be used as substitutions or replacements:

74030	Center Rail Insulators	C-Track	
74040	Feeder Wire Set	C-Track	
74043	Signal Hookup Kit	C-Track	(Contains 74030 & 74040)
7522	Center Rail Insulators	K-Track	
7504	Center Rail Terminals	K-Track	

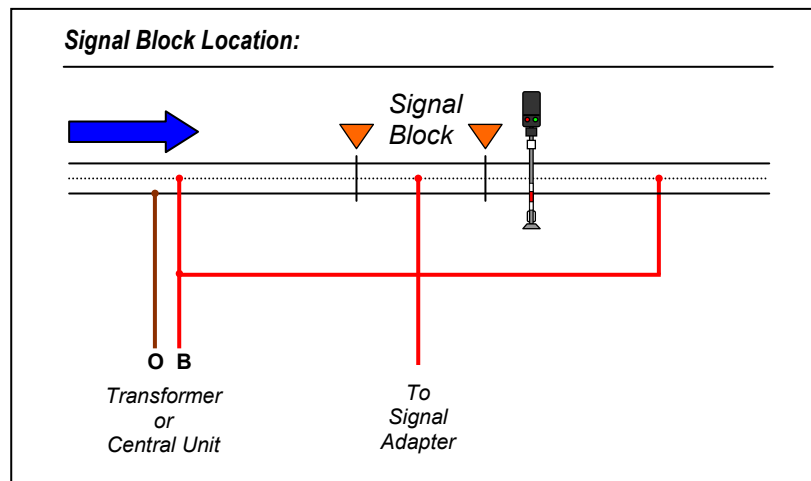

Figure 1. Signal Block Installation

3.1.2 Signal Mast Installation:

- 2) Carefully remove the two top cover halves of the grey plastic signal base. They are each held to the base by three small pins. Removal is easiest when beginning from the open area of the base adjacent to the track roadbed. Once the cover has been slightly lifted, position a fingernail into the opening between the cover and base, and then slide it along the edge of the base. Work slowly and carefully to avoid damaging the signal mast.
- 3) With the two cover halves removed, carefully slide the signal mast backwards to remove it from the signal base. This is best done using a thumbnail directly at the foot of the mast, pushing the mast backward with very gentle pressure.
- 4) The connector can now be removed from the signal base by pushing the wires upward first to release the connector from the base, and then pulling the wires and connector downward through the opening.
- 5) If using C track, install the base in the desired position next to the track using the roadbed clip. If using K track, first carefully remove the roadbed clip on the base using diagonal wire cutters, an Xacto knife, razor blade,

razor saw, etc. (always use caution when working with sharp tools!). Then position the base beside the track, secure with tape if necessary.

- 6) Next, drill two small pilot holes (1/32" diameter) through the benchwork for the mounting screw and the wire assembly. Then remove the base, and enlarge the hole for the wire assembly using a 3/16" (or slightly larger) diameter drill bit.

3.1.3 Signal Adapter Installation:

- 7) Position the *Signal Adapter* in the desired location under the layout, preferably close to the position of the signal. Drill two pilot holes (1/16" diameter or less) and install the adapter using the supplied mounting screws.

3.1.4 Final Installation:

- 8) With the adapter installed, the signal wiring and connector assembly can now be fed through the hole in the benchwork created in step 6 above.
- 9) Pull a few inches of the wiring assembly through the benchwork, and reinstall the connector in the signal base. Position the appropriate grade leveling piece under the base if necessary, and mount the base to the benchwork using the supplied mounting screw.
- 10) Carefully reinstall the signal mast and cover halves onto the base. Installation of the signal track block, mast, and *Signal Adapter* is now complete!



3.2 Connecting the Signal Adapter

The *Signal Adapter* is operated in the same way as a conventional Märklin color light or semaphore signal. The two blue Pulse Input leads control the signal aspect, red or green. These two wires should be connected to a momentary analog switch box, circuit tracks, or the outputs of a digital accessory decoder like the *MZE Decoder Z83/84* or Märklin k83. Power to the *Signal Adapter* can be supplied from several different sources since the adapter contains an internal rectifier stage to generate DC power for the signal LEDs and onboard relay. The recommended power source is the L-O (16VAC) accessory output of a standard Märklin transformer. This allows for division of power between the train operations and accessories such as signals, lighting, turnouts, etc. However, the *Signal Adapter* may also be powered from the Yellow (-22VDC) and Brown terminals of a digital accessory decoder or directly to the digital track power ($\pm 22V$) on a digital layout. The Auxillary Switch Outputs of the *Signal Adapter* are double-throw contacts, and are provided for control panel feedback LED connections or basic on/off train control. Please follow the steps and diagrams below to properly connect the *Signal Adapter* to your layout.

- 1) Be sure that all power to the layout is completely switched OFF before performing any connections. There are several ways to connect the Pulse and Power Inputs, depending on which controller and power source are being used. In all cases, the controller and power source grounds should be connected to a common ground ("0").
 - 1a) If the *Signal Adapter* is to be controlled by a digital accessory decoder, the Pulse and Power Inputs may be connected in any of the three configurations shown in Figure 2 below. (Note: A conventional Märklin signal **can not** be separately powered by 16VAC or the digital track power while being controlled by a digital accessory decoder as shown in Figure 2. The *Signal Adapter* is different in that it uses a negatively powered DC relay, so that it will not damage the accessory decoder outputs when it is powered by 16VAC or digital track power.)
 - 1b) If the *Signal Adapter* will be operated using analog controllers, such as a momentary switchbox or circuit track, the Pulse and Power Inputs should be connected as shown in either Figure 3a or 3b. (Note: When using 16VAC power as in Figure 3a, the power source for train operations is independent of the *Signal Adapter* and may be either a conventional train control transformer or digital controller. If a conventional transformer is used for train operations on smaller layouts, its 16VAC L-O accessory output may be used in place of the separate accessory transformer shown in Figure 3a.)
- 2) The Auxillary Switch outputs can be connected to the signal track block created in Section 3.1.1 to provide on/off style train control as shown in Figure 4. They may also be used for layout control panel feedback with LEDs or other logic or control functions. (Note: The 1N4148 diodes connected in anti-parallel across the feedback LEDs are necessary to protect the LEDs from the reverse AC voltage swing.)
- 3) Once all of the appropriate connections have been made, be sure to test all of the functions and enjoy remotely operating the new generation Märklin LED signals with the *MZE Signal Adapter*!

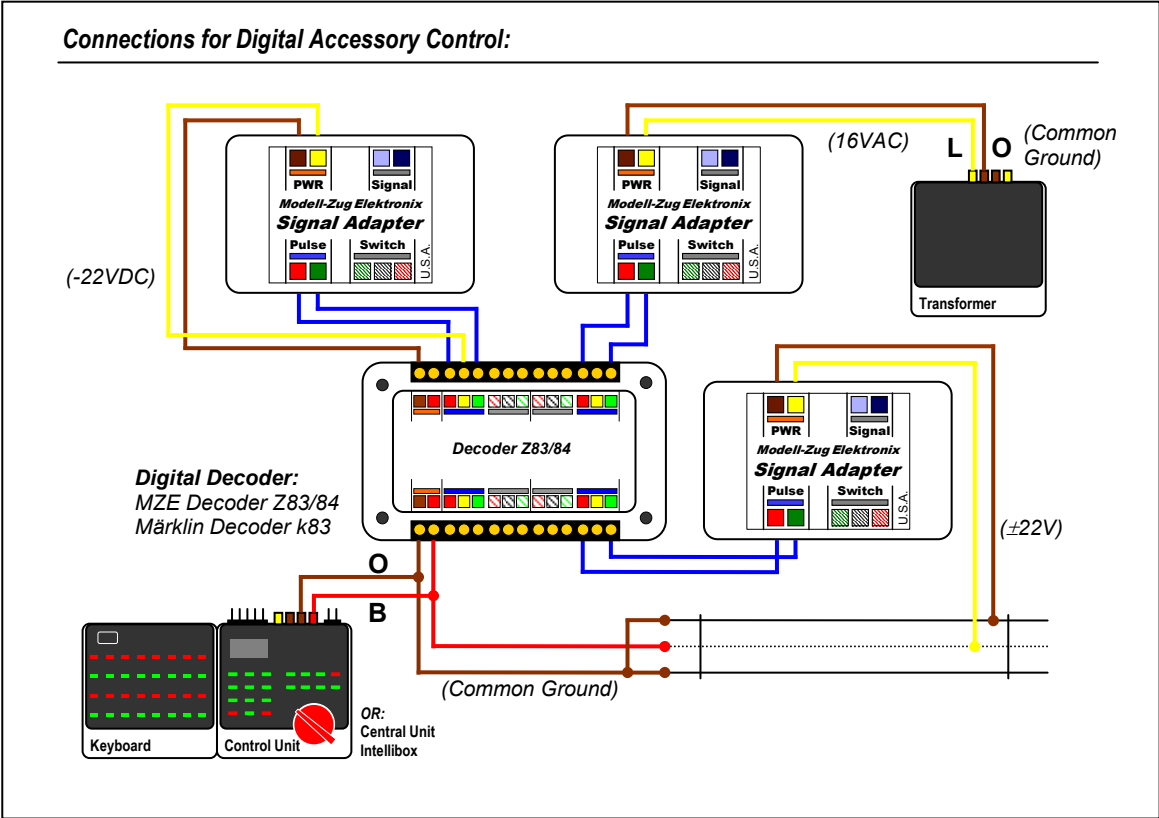

Figure 2. Input Connections – Digital Control

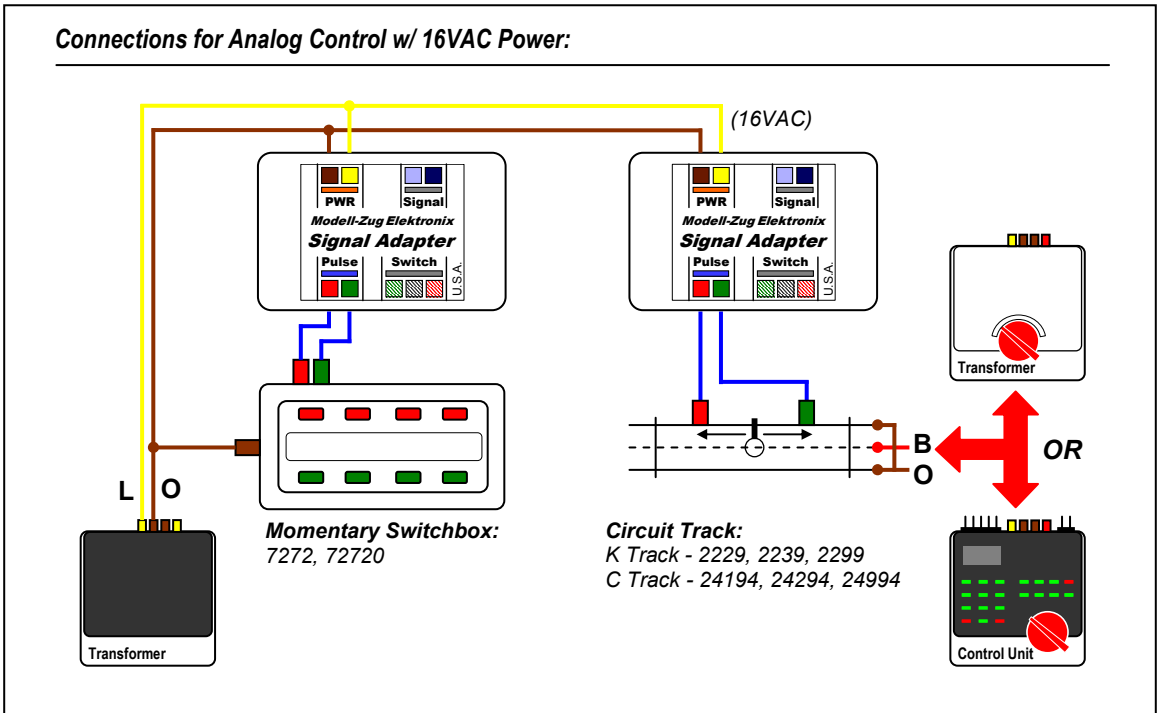

Figure 3a. Input Connections – Analog Control & 16VAC Power

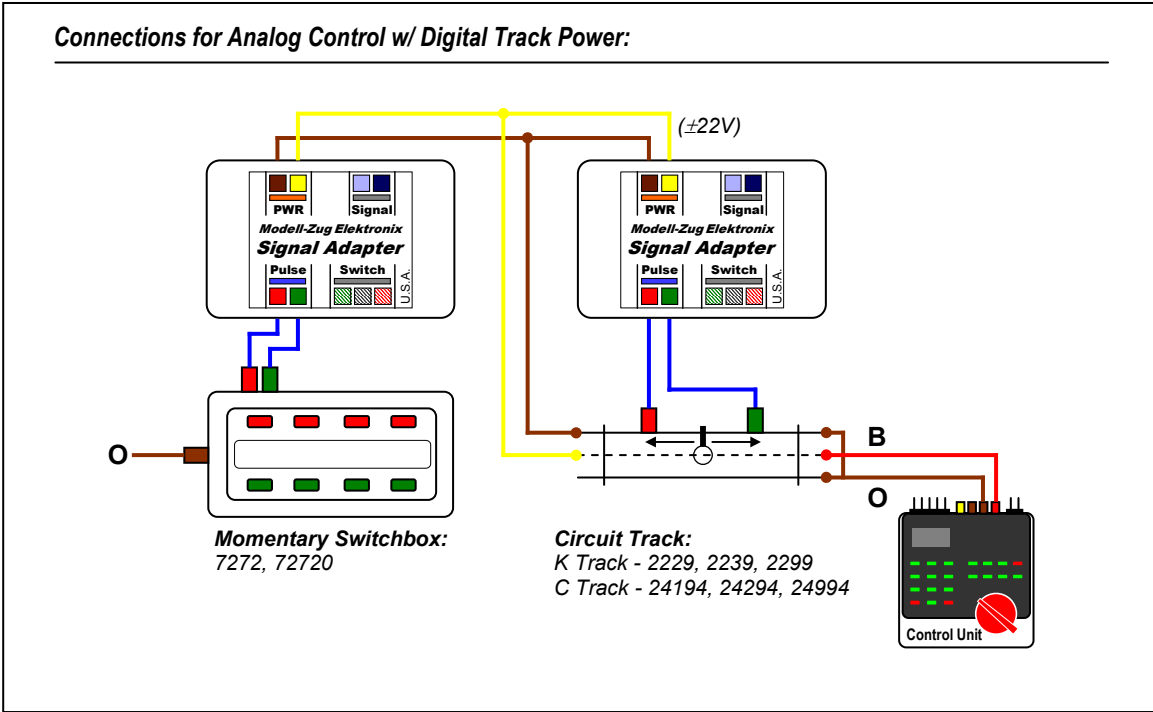

Figure 3b. Input Connections – Analog Control & Digital Track Power

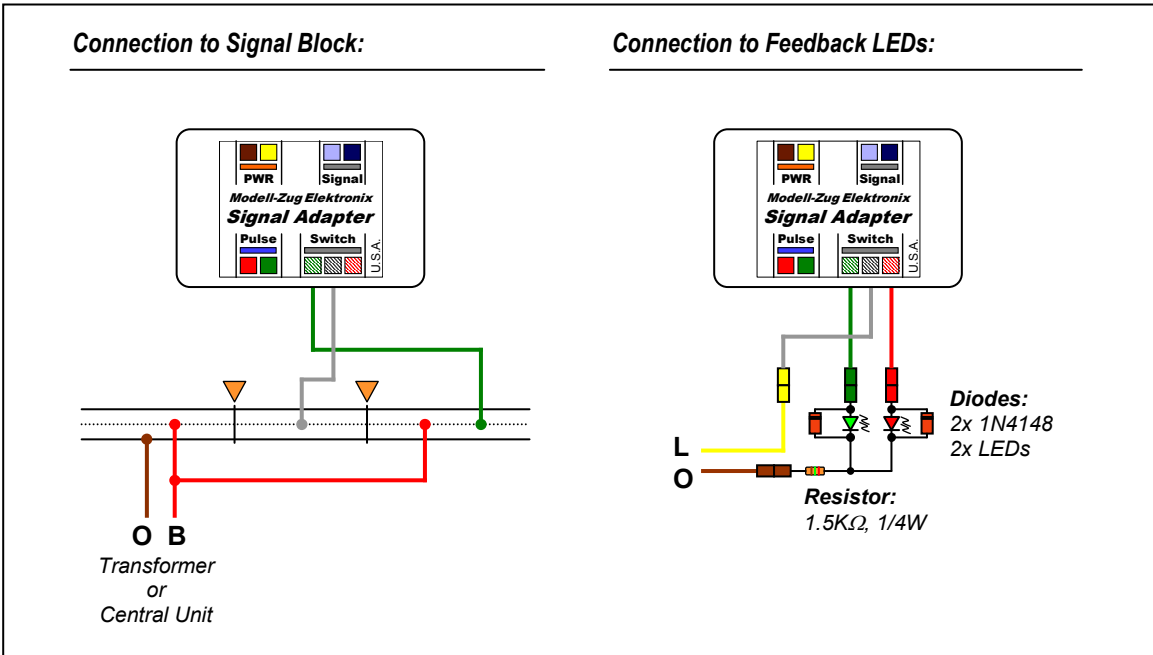

Figure 4. Auxillary Switch Connections